



Selecta

Urus





The new generation of Selecta stoves recalls nostalgic winter scenes in front of the stove. The Selecta series is synonymous with simplicity and reliability thanks to its simple, elegant design and excellent heating technology. Anyone who opts for high efficiency, low emissions and a wonderful feeling of warmth at a great price will definitely find what they are looking for with Selecta.



Urur Classic



Urur Style



Belgian quality

The Selecta family of stoves is top Belgian quality, produced in one of the best foundries in the world.

This means you benefit from high-quality cast iron (GJL-150), used in a perfected product.

Airwash & clean burn system

The Selecta Airwash smoke extraction system uses a baffle to circulate secondary combustion air along the window. This eliminates unburned combustion gases and condensation on the glass so that it remains clean for longer.

Self-cleaning premium windows

By using premium ceramic glass with a heat-reflective coating, some infrared rays are reflected. This increases the temperature in the combustion chamber and improves combustion. The temperature of the window itself also increases, so the soot particles burn off the glass surface and the window remains perfectly clean.

Secondary combustion: high efficiency and cleaner environment

The new generation of Selecta stoves is equipped with a unique double combustion system. Secondary air enters the stove from the rear. It is then first heated there and then sent into the heating body. A secondary combustion follows which ignites the gases not completely consumed again. Result: higher heat output and cleaner, more environmentally friendly combustion.

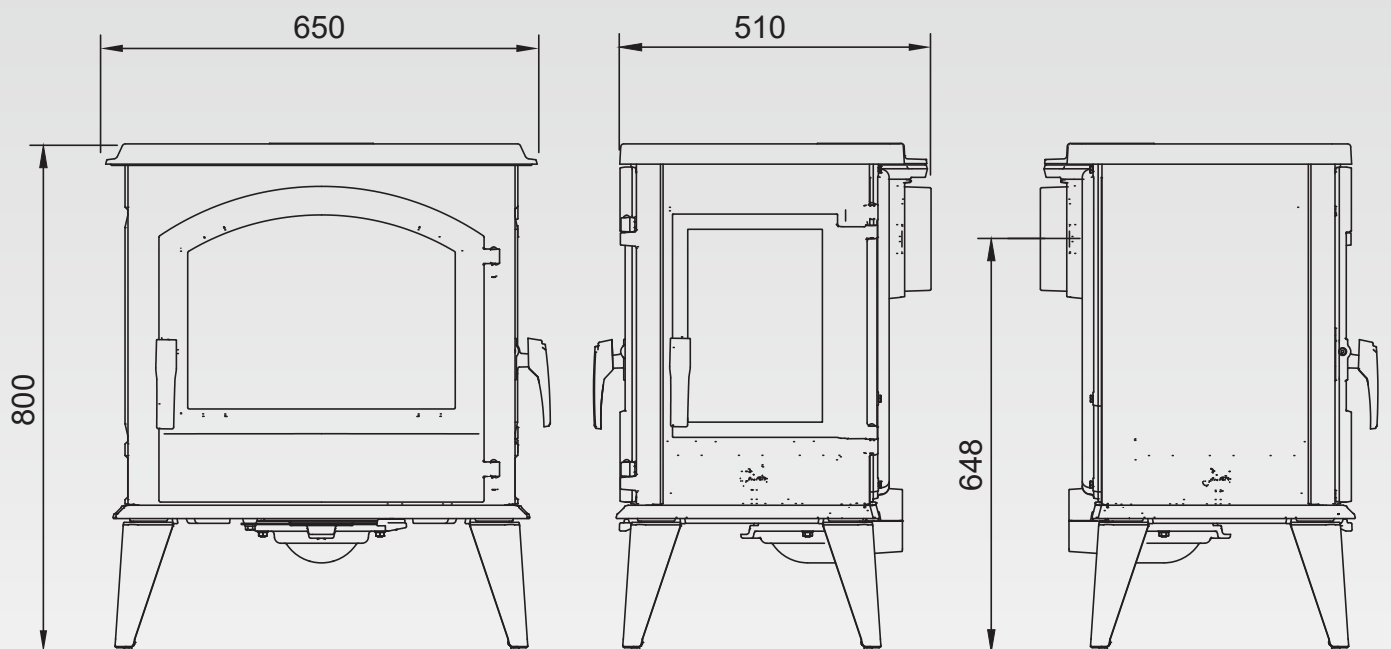

Classic

Urus Classic

Specifications



Features

- User-friendly cargo door
- Airwash & clean burn system
- External air connection
- Black lacquered cast iron
- Product efficiency >80%
- Place smoke outlet above or behind

Specifications

Nominal power	9kW
Partial load power	4,9kW
Efficiency >80%	>80%
H x W x D mm	800x650x510
Weight	180 kg
fuel	wood
wood logs	45cm
Side-fill door	yes
Sec. combustion	included
External air connection	included
Smoke outlet above or behind	included
Diameter chimney connection	150mm

Meet the requirements of EN 16510-2-1 : 2023-06 and EN 16510-1 : 2023-06



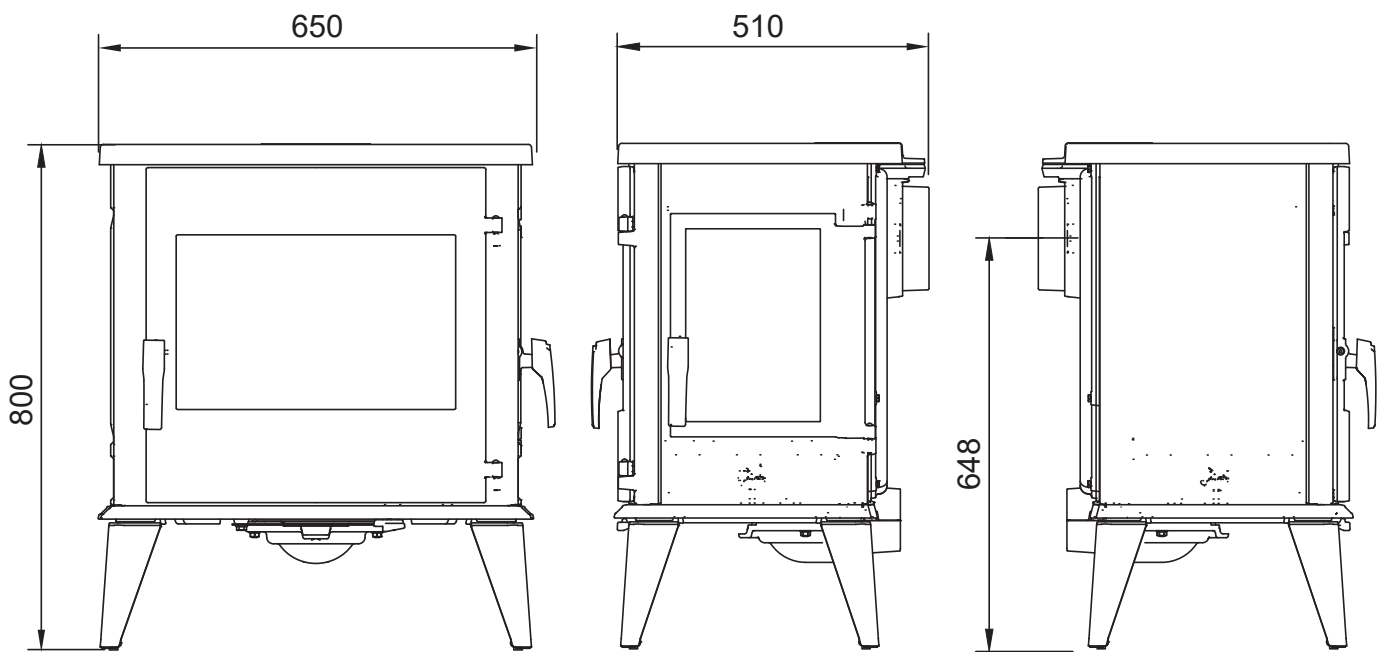

Style

Urus Style



Specifications



Features

- User-friendly cargo door
- Airwash & clean burn system
- External air connection
- Black lacquered cast iron
- Product efficiency >80%
- Place smoke outlet above or behind

Specifications

Nominal power	9 kW
Partial load power	4,9kW
Efficiency >80%	>80%
H x W x D mm	800x650x510
Weight	180 kg
fuel	wood
wood logs	45cm
Side-fill door	yes
Sec. combustion	included
External air connection	included
Smoke outlet above or behind	included
Diameter chimney connection	150mm

Meet the requirements of EN 16510-2-1 : 2023-06 and EN 16510-1 : 2023-06





www.selectastoves.com

In the context of continuous product improvement, specifications of the supplied device may differ from the description in this brochure, without prior notice.
Subject to typographical errors and printing errors.

